

Lift&Drive



Lift&Drive

90P

 PRONOMIC

Lift&Drive 90P

Lifters based on modular design, make it suit your requirements

Our self-manufactured lift trolley with a lifting capacity of 90 kg. Your requirements determine the appearance of the final lifter.

The light-weight trolley are flexible and equipped with a directional lock on the rear wheels, this make it maneuverable and quick and easy to turn sideways. The trolley are very simple to use and easy to handle, and it require only very little maintenance.

The column are equipped with a screw drive and are available in different heights.

To ensure maximal safety the trolley possess a built-in release function, which serves as protection from crushing injuries and prevents the trolley from tipping over.

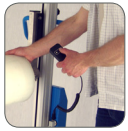

Detachable manual control box



Screw drive with coaster function to prevent crushing injuries and the trolley tipping over

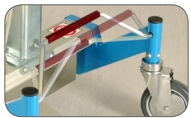

Central brake and directional lock on the rear wheels

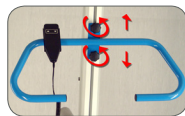

Height-adjustable handlebar



Module-based design -

your requirements and working environment determine the final tool

- 1 Pair of legs
- 2 Electronic unit
- 3 Control box
- 4 Mast
- 5 Intermediate section
- 6 Handlebar
- 7 Charger

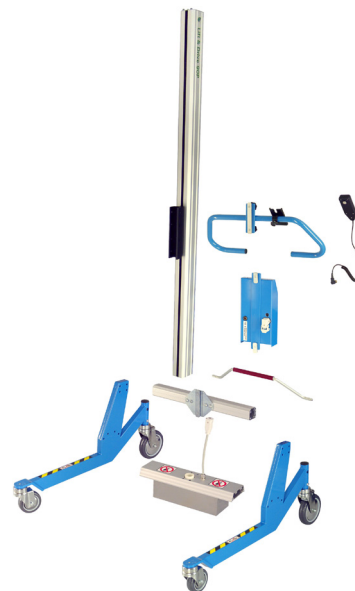
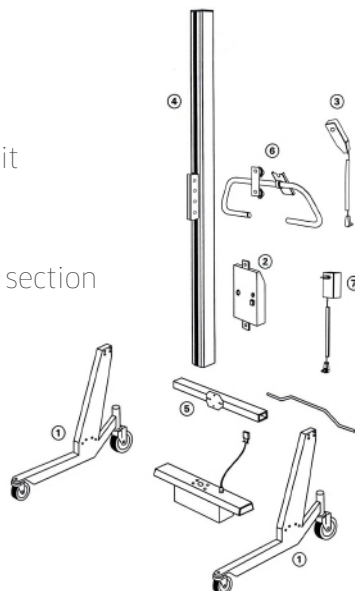

Accessories - standard or customized

Select an accessory you require from our broad range of standard tools: prong for roll handling, roll platform, lifting forks, as well as our Squeeze&Turn modules; weighing scales and counting scales, etc. We also manufacture customized tools in accordance to your specifications.



Standard loading platform



Prong for roll handling



Fork



Roll platform, with front-feed



Roll platform, with side-feed



Scales



Squeeze&Turn



Expand&Turn - pneumatic expander, turning operated electrically

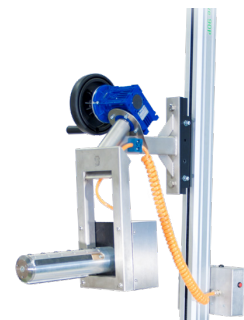

Expand&Turn - pneumatic expander, turning operated manually

Flexibility - choose mast height, and width & length of legs



Technical Specifications

Technical Specifications for Lift&Drive, 90P

	Overall height, standard	Overall height, low built	Total lifting height, standard	Total lifting height, low built	Length of stroke
Standard	<u>1732</u>	<u>1681</u>	<u>1234</u>	<u>1184</u>	<u>1192</u>
+250	1982	1931	1484	1434	1442
+500	2232	2181	1734	1684	1692
Minimum lifting height			40 mm		
Overall width			733 mm to 1573 mm		
Length (without loading platform) standard, low-built			904, 881 mm		
Minimum width(outside)			490 mm		
Maximum width (outside)			1390 mm		
Loading platform (LxW), standard			420x400 mm		
Wheel diameter (front/rear) standard, low-built			100/150, 60/100 mm		
Maximum load 90P			90 kg		
Dead weight			From 38 kg		
Battery voltage			24 V		
Battery capacity			7.2 Ah		
Charging voltage			230VAC/50Hz or 115VAC/60Hz		
Lifting height with max. load for 90P			5.4 m/min up. 7.6 m/min down		
Material			Chassis in powder-coated steel		

Underlined values apply for standard trolley

For further info
please contact your
sales representative



PRONOMIC AB
info@pronomic.se
www.pronomic.se

SMEYERS-TU NV/SA
Tref 61 / 3 B-1853 Strombeek-Bever
☎ 02-461 21 09 ☎ 02-461 21 44
www.pronomic-lift.be

 **PRONOMIC**